

# STANDARD SERIES CLAMPS – ORDERING EXAMPLE

**\*\*A3 – 21.3 – A**

CLAMP SET MATERIAL	
Polypropylene (Green)	A
Polyamide*	MA
Rubber*	RA

\* SPECIAL ORDER

**GROUP SIZE**  
Refer to Chart on Page 87

**CLAMP SET ID**  
Refer to Chart on Page 87

DESCRIPTION	
<b>A</b>	Clamp with Weld Plate & Cover Plate
<b>B</b>	Clamp with Weld Plate & No Cover Plate
<b>SK</b>	Clamp with Stacking Kit
<b>E</b>	Clamp with Elongated Weld Plate & Cover Plate
<b>R</b>	Clamp with Rail Nuts & Cover Plate
<b>■</b>	Clamp Set Only

**CLAMP SET BORE**  
Pipe and tube clamp sizes have a profiled bore. For hose and special applications add "H" to the part number for a smooth bore.

\*\* "S" PREFIX = STAINLESS STEEL HARDWARE

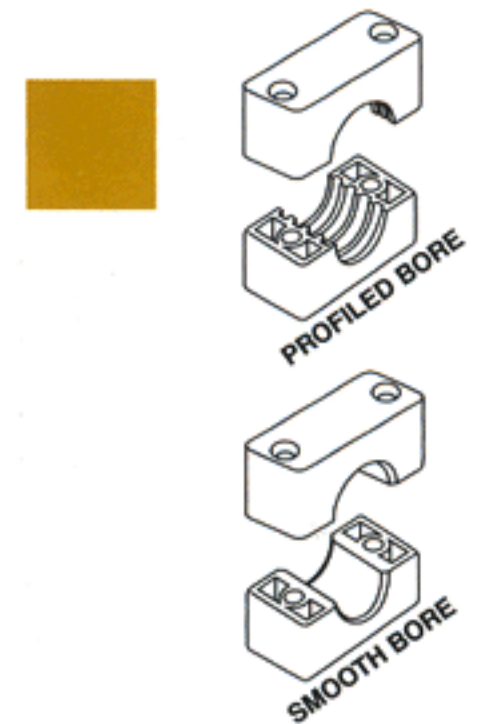
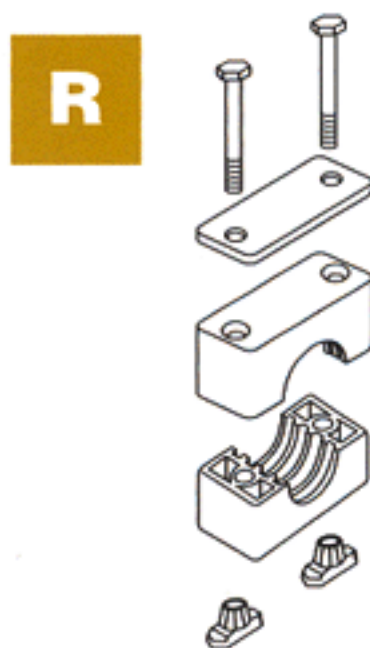
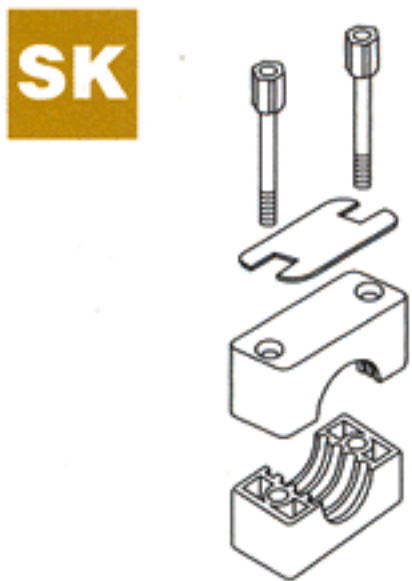
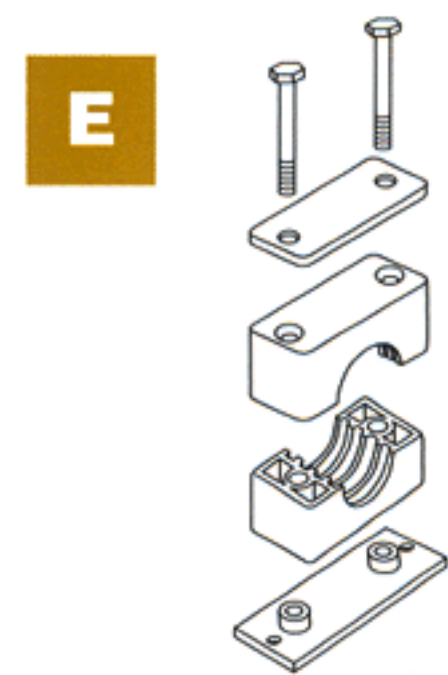
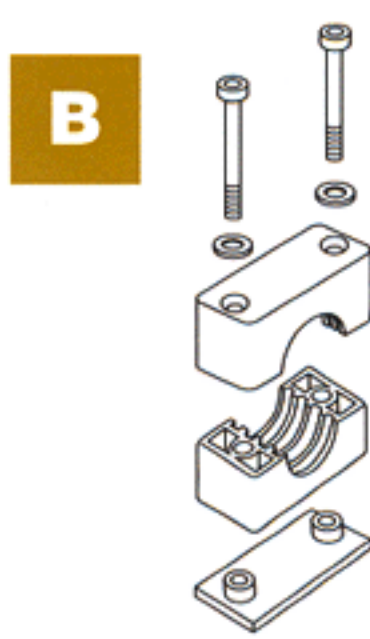
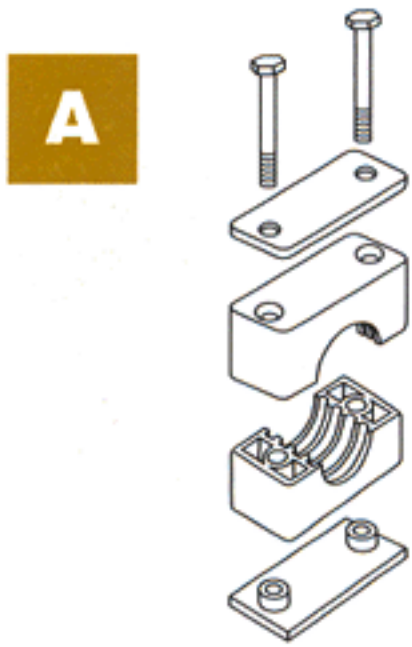

❶ NOT AVAILABLE IN ALL SIZES. CONTACT PCI FOR AVILABILITY.



# STANDARD SERIES – SIZES AND DIMENSIONS

**Group 0**

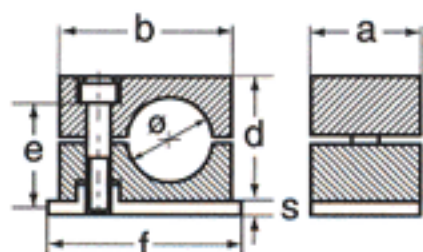

**Group 1-6**

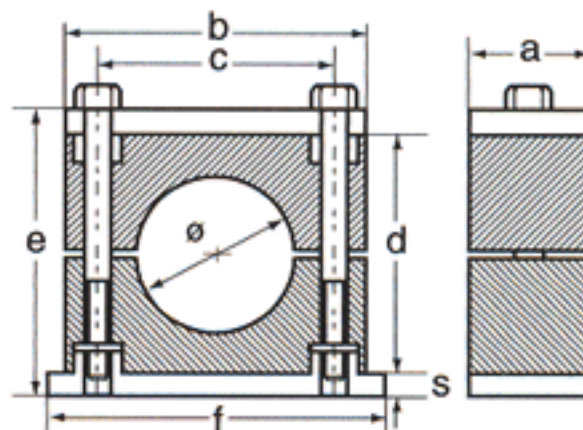

PCI	DIN	DIAMETER					DIMENSIONS						
GROUP	GROUP	Ø mm	Inch	PIPE NOMINAL BORE	TUBE O.D.	PART #	A	B	C	D	F	S	H
0	0	6	0.24			A0-06-A							
		8	0.31		5/16"	A0-08-A	30mm	28mm	–	27mm	32mm	3mm	33mm
		10	0.39	1/8"		A0-10-A	1.18"	1.10"	–	1.06"	1.26"	.12"	1.30"
		12	0.47			A0-12-A							
1	1	6	0.24			A1-06-A							
		6.4	0.25		1/4"	A1-6.4-A							
		8	0.31		5/16"	A1-08-A	30mm	34mm	20mm	27mm	42mm	3mm	33mm
		9.5	0.37		3/8"	A1-9.5-A	1.18"	1.34"	.79"	1.06"	1.65"	.12"	1.30"
		10	0.39	1/8"		A1-10-A							
2	2	12	0.47			A1-12-A							
		12.7	0.50		1/2"	A2-12.7-A							
		13.5	0.53	1/4"		A2-13.5-A							
		14	0.55			A2-14-A							
		15	0.59			A2-15-A	30mm	40mm	26mm	33mm	48mm	3mm	39mm
		16	0.63		5/8"	A2-16-A	1.18"	1.57"	1.02"	1.30"	1.89"	.12"	1.54"
3	3	17.2	0.67	3/8"		A2-17.2-A							
		18	0.71			A2-18-A							
		19	0.75			A2-19-A							
		19	0.75		3/4"	A3-19-A							
		20	0.79			A3-20-A							
4	4	21.3	0.84	1/2"		A3-21.3-A	30mm	45mm	33mm	35mm	55mm	3mm	41mm
		22	0.87		7/8"	A3-22-A	1.18"	1.69"	1.30"	1.38"	2.17"	.12"	1.61"
		25	0.98			A3-25-A							
		25.4	1.00		1"	A3-25.4-A							
5	5	26.9	1.06	3/4"		A4-26.9-A							
		28	1.10			A4-28-A	30mm	57mm	40mm	42mm	62mm	3mm	48mm
		30	1.18			A4-30-A	1.18"	2.24"	1.57"	1.65"	2.44"	.12"	1.89"
		32	1.25		1 1/4"	A4-32-A							
6	6	32	1.25			A5-32-A							
		33.7	1.33	1"		A5-33.7-A							
		35	1.38			A5-35-A							
		38	1.50		1 1/2"	A5-38-A	30mm	68mm	52mm	58mm	74mm	3mm	64mm
		40	1.57			A5-40-A	1.18"	2.68"	2.05"	2.28"	2.91"	.12"	2.52"
		42	1.65			A5-42-A							
7	7	42.4	1.67	1 1/4"		A5-42.4-A							
		45	1.77			A5-45-A							
		44.5	1.75		1 3/4"	A6-44.5-A	30mm	86mm	66mm	66mm	88mm	3mm	77mm
8	8	48.3	1.90	1 1/2"		A6-48.3-A	1.18"	3.39"	2.60"	2.60"	3.46"	.12"	2.83"
		50.8	2.00		2"	A6-50.8-A							

ADD "S" PREFIX FOR STAINLESS STEEL HARDWARE WHEN ORDERING A COMPLETE CLAMP ASSEMBLY.



# STANDARD SERIES – COMPONENTS

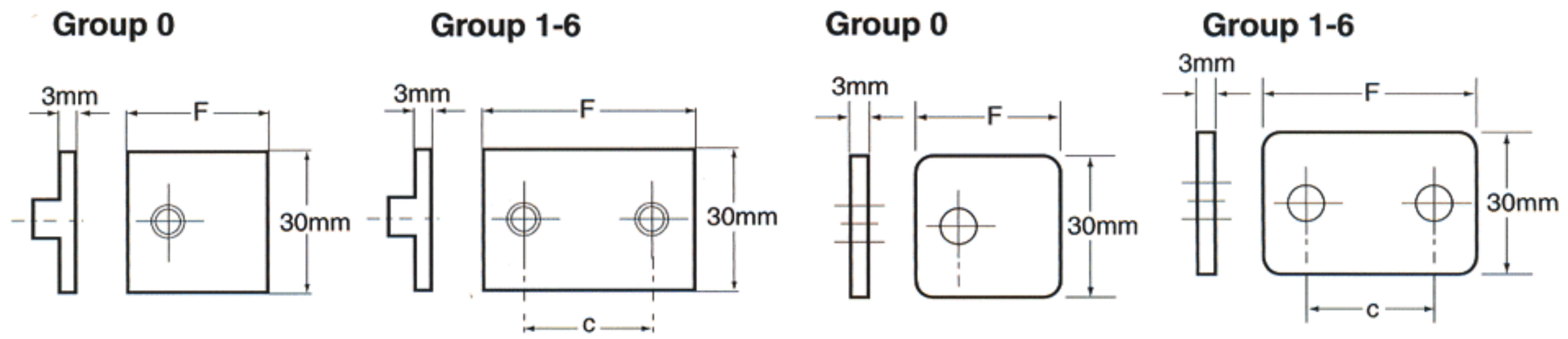

**WELD PLATE**

**COVER PLATE**

GROUP	PART NUMBER	DIMENSIONS		PART NUMBER	DIMENSIONS	
		F	C		F	C
0	WP0	32mm 1.28"	— 0.00"	CP0	28mm 1.10"	— 0.00"
1	WP1	42mm 1.65"	20mm 0.79"	CP1	37mm 1.46"	20mm 0.79"
2	WP2	48mm 1.89"	26mm 1.02"	CP2	43mm 1.69"	26mm 1.02"
3	WP3	55mm 2.17"	33mm 1.30"	CP3	50mm 1.97"	33mm 1.30"
4	WP4	62mm 2.44"	40mm 1.57"	CP4	57mm 2.24"	40mm 1.57"
5	WP5	74mm 2.91"	52mm 2.05"	CP5	69mm 2.72"	52mm 2.05"
6	WP6	88mm 3.46"	66mm 2.60"	CP6	83mm 3.27"	66mm 2.60"

ADD "S" PREFIX FOR STAINLESS STEEL HARDWARE.

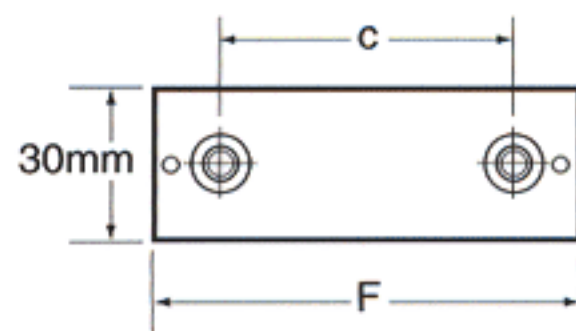

**ELONGATED WELD PLATE**

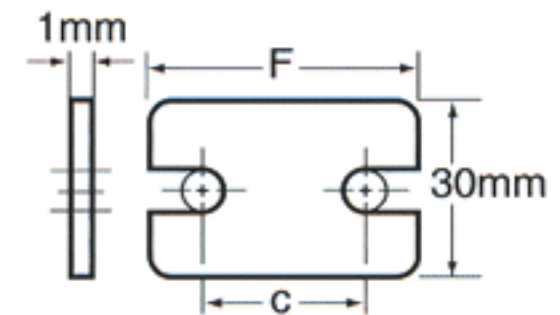

**SAFETY PLATE**

GROUP	PART NUMBER	DIMENSIONS			PART NUMBER	DIMENSIONS	
		F	c	d		F	c
0	EWP0	46mm 1.81"	— 0.00"	— 0.00"	SP0	28mm 1.10"	— 0.00"
1	EWP1	64mm 2.52"	20mm 0.79"	50mm 2.01"	SP1	34mm 1.34"	20mm 0.79"
2	EWP2	70mm 2.76"	26mm 1.02"	56mm 2.20"	SP2	41mm 1.61"	26mm 1.02"
3	EWP3	78mm 3.07"	33mm 1.30"	64mm 2.52"	SP3	47mm 1.85"	33mm 1.30"
4	EWP4	86mm 3.39"	40mm 1.57"	71mm 2.80"	SP4	57mm 2.24"	40mm 1.57"
5	EWP5	97mm 3.82"	52mm 2.05"	83mm 3.27"	SP5	67mm 2.64"	52mm 2.05"
6	EWP6	112mm 4.41"	66mm 2.60"	100mm 3.94"	SP6	82mm 3.23"	66mm 2.60"

ADD "S" PREFIX FOR STAINLESS STEEL HARDWARE.



# STANDARD SERIES – COMPONENTS

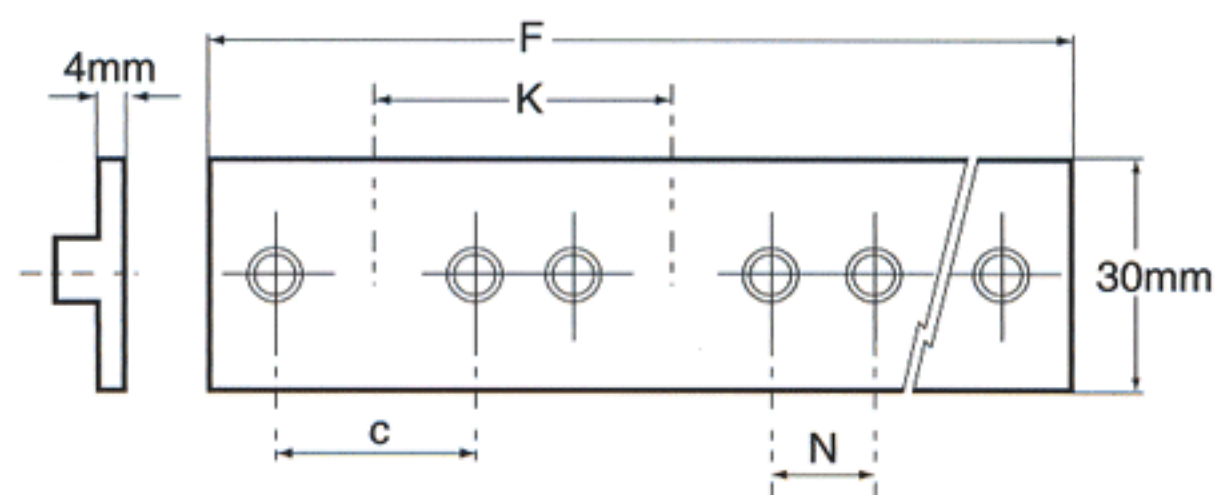
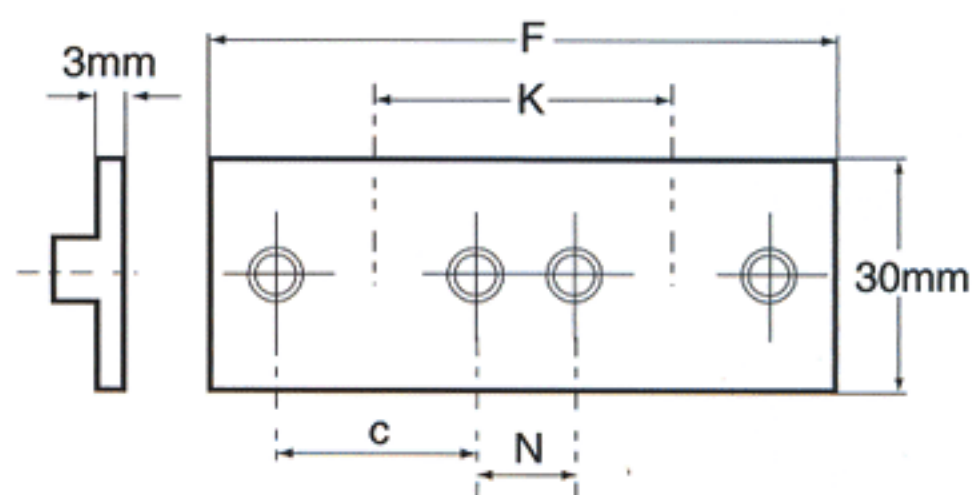

**DOUBLE WELD PLATE**

**MULTIPLE WELD PLATE**

GROUP	PART NUMBER	DIMENSIONS				PART NUMBER	DIMENSIONS				NUMBER OF CLAMPS PER PLATE
		F	C	N	K		F	C	N	K	
0	DWP0	61mm 2.40"	—	—	30mm 1.18"	MWP0	306mm 12.05"	—	—	30mm 1.18"	10
1	DWP1	81mm 3.19"	20mm 0.79"	20mm 0.79"	40mm 1.57"	MWP1	404mm 15.91"	20mm 0.79"	20mm 0.79"	40mm 1.57"	10
2	DWP2	91mm 3.58"	26mm 1.02"	18mm 0.71"	44mm 1.73"	MWP2	447mm 17.60"	26mm 1.02"	18mm 0.71"	44mm 1.73"	10
3	DWP3	106mm 4.17"	33mm 1.30"	19mm 0.75"	52mm 2.05"	MWP3	525mm 20.67"	33mm 1.30"	19mm 0.75"	52mm 2.05"	10
4	DWP4	121mm 4.76"	40mm 1.57"	20mm 0.79"	60mm 2.36"	MWP4	303mm 11.93"	40mm 1.57"	20mm 0.79"	60mm 2.36"	5
5	DWP5	148mm 5.83"	52mm 2.05"	23mm 0.91"	75mm 2.95"	MWP5	375mm 14.76"	52mm 2.05"	23mm 0.91"	75mm 2.95"	5
6	DWP6	177mm 6.97"	66mm 2.60"	24mm 0.94"	90mm 3.54"	MWP6	447mm 17.60"	66mm 2.60"	24mm 0.94"	90mm 3.54"	5

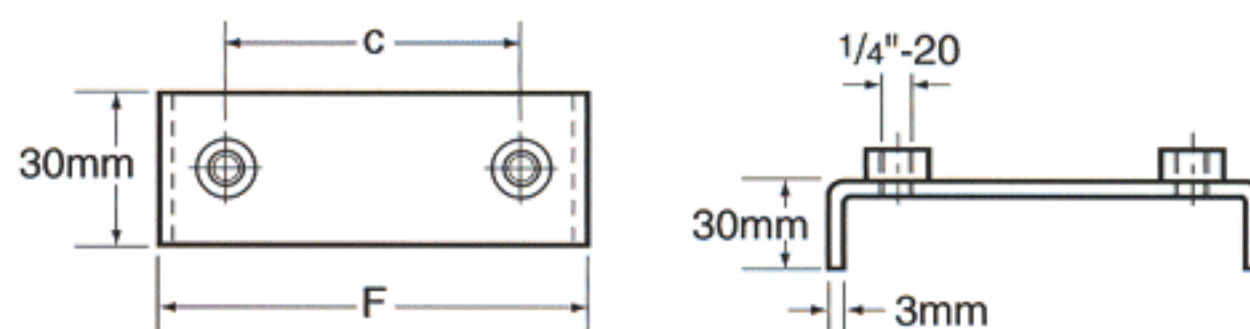
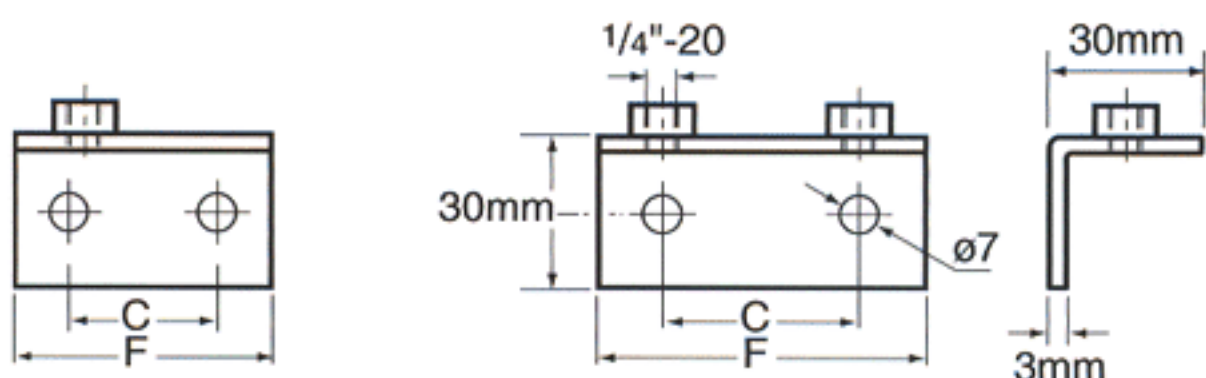

**ANGLED WELD PLATE**

**BRIDGE WELD PLATE**

GROUP	PART NUMBER	DIMENSIONS		PART NUMBER	DIMENSIONS	
		F	C		F	C
0	AWP0	32mm 1.26"	14mm 0.55"	—	—	—
1	AWP1	42mm 1.65"	20mm 0.79"	BWP1	48mm 1.89"	20mm 0.79"
2	AWP2	48mm 1.89"	26mm 1.02"	BWP2	54mm 2.13"	26mm 1.02"
3	AWP3	55mm 2.17"	33mm 1.30"	BWP3	62mm 2.44"	33mm 1.30"
4	AWP4	62mm 2.44"	40mm 1.57"	BWP4	71mm 2.80"	40mm 1.57"
5	AWP5	74mm 2.91"	52mm 2.05"	BWP5	85mm 3.35"	52mm 2.05"
6	AWP6	88mm 3.46"	66mm 2.60"	BWP6	98mm 3.86"	66mm 2.60"



# STANDARD SERIES – COMPONENTS

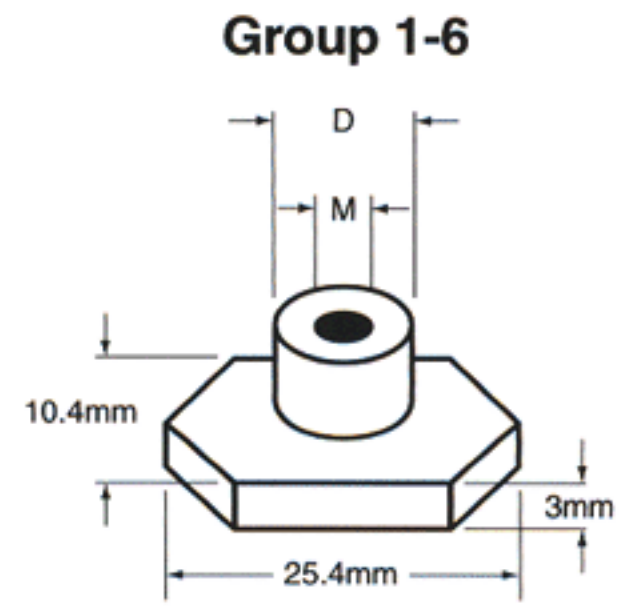
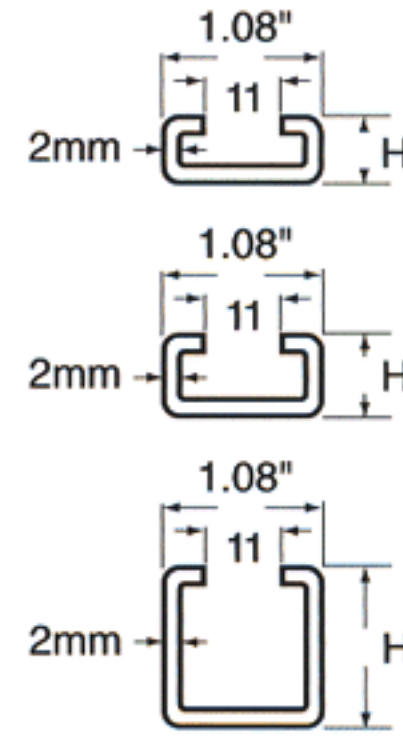
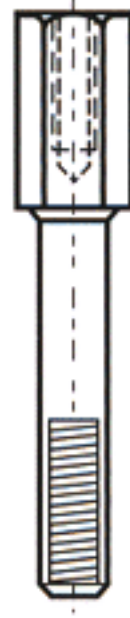
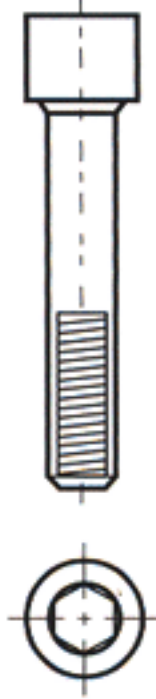

GROUP	HEX HEAD BOLT	SOCKET HEAD CAP SCREW	STACKING BOLT	MOUNTING RAIL		RAIL NUT	
	PART NUMBER SIZE	PART NUMBER SIZE	PART NUMBER SIZE	PART NUMBER HEIGHT H	PART NUMBER LENGTH L	PART NUMBER M	PART NUMBER D
0	HB0/1 1/4"-20 x 11/4"	SC0/1 1/4"-20 x 3/4"	SB0/1 1/4"-20 x 3/4"	MR-11-1 11 0.43	1M 3.28	RNS/T1 1/4"-20	12mm 0.47"
1	HB0/1 1/4"-20 x 11/4"	SC0/1 1/4"-20 x 3/4"	SB0/1 1/4"-20 x 3/4"	MR-11-2 11 0.43	2M 6.56		
2	HB2 1/4"-20 x 13/8"	SC2 1/4"-20 x 1"	SB2 1/4"-20 x 1"	MR-14-1 14 0.55	1M 3.28		
3	HB3 1/4"-20 x 11/2"	SC3 1/4"-20 x 11/4"	SB3 1/4"-20 x 11/4"	MR-14-2 14 0.55	1M 6.56		
4	HB4 1/4"-20 x 13/4"	SC4 1/4"-20 x 13/8"	SB4 1/4"-20 x 13/8"	MR-30-1 30 1.18	1M 3.28		
5	HB5 1/4"-20 x 21/2"	SC5 1/4"-20 x 2"	SB5 1/4"-20 x 2"	MR-30-2 30 1.18	2M 6.56		
6	HB6 1/4"-20 x 23/4"	SC6 1/4"-20 x 23/8"	SB6 1/4"-20 x 23/8"				

ADD "S" PREFIX FOR STAINLESS STEEL BOLTS.