

STANDARD SERIES CLAMPS – ORDERING EXAMPLE

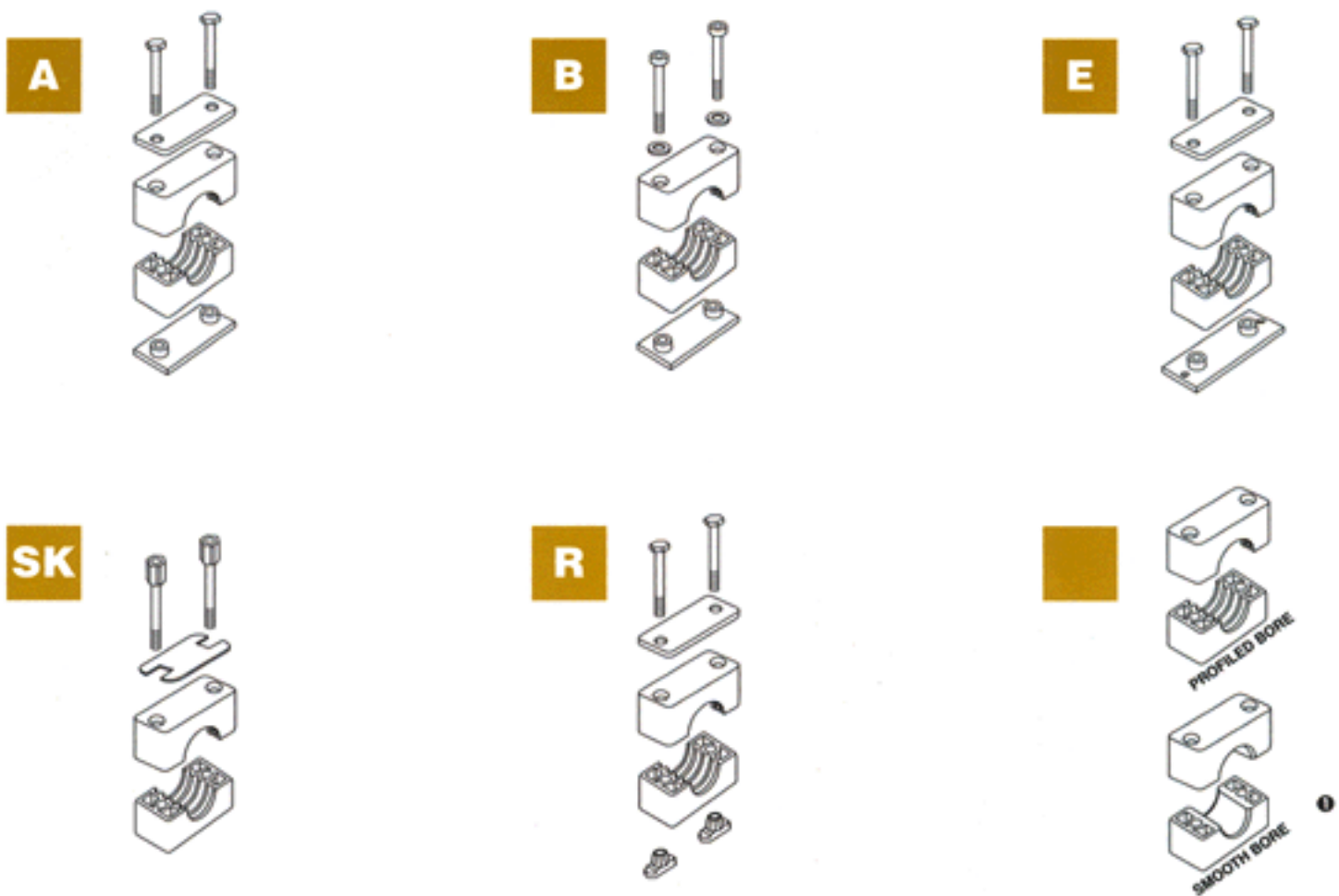
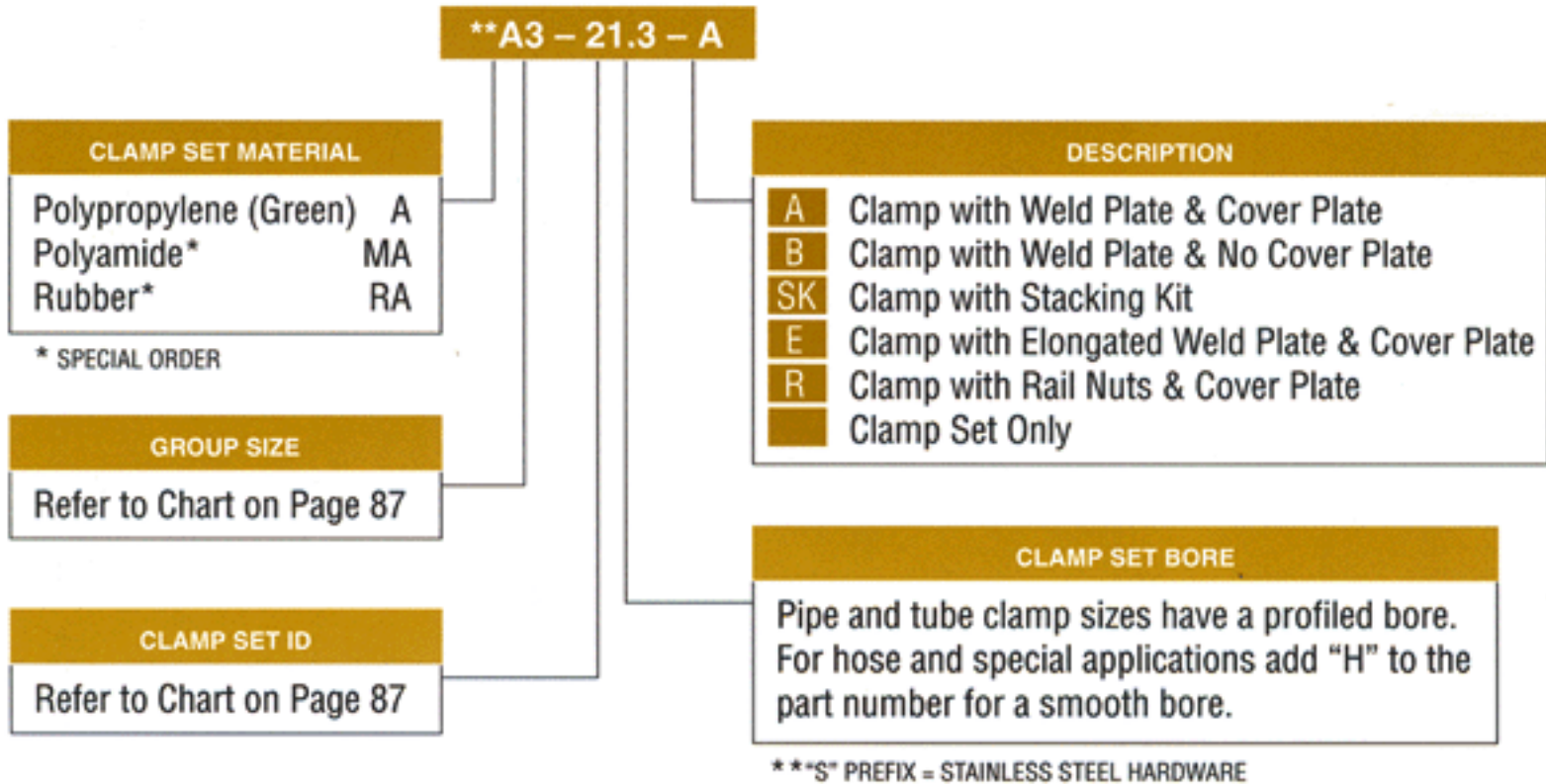

❶ NOT AVAILABLE IN ALL SIZES. CONTACT PCI FOR AVILABILITY.

STANDARD SERIES – SIZES AND DIMENSIONS

Group 0

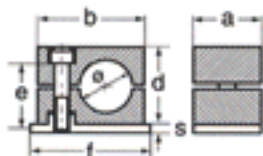

Group 1-6

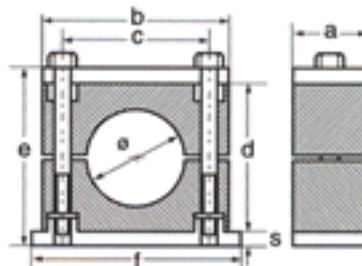

PCI	DIN	DIAMETER					DIMENSIONS						
GROUP	GROUP	Ø mm	Inch	PIPE NOMINAL BORE	TUBE O.D.	PART #	A	B	C	D	F	S	H
0	0	6	0.24			A0-06-A							
		8	0.31		5/16"	A0-08-A	30mm	28mm	–	27mm	32mm	3mm	33mm
		10	0.39	1/8"		A0-10-A	1.18"	1.10"	–	1.06"	1.26"	.12"	1.30"
		12	0.47			A0-12-A							
1	1	6	0.24			A1-06-A							
		6.4	0.25		1/4"	A1-6.4-A							
		8	0.31		5/16"	A1-08-A	30mm	34mm	20mm	27mm	42mm	3mm	33mm
		9.5	0.37		3/8"	A1-9.5-A	1.18"	1.34"	.79"	1.06"	1.65"	.12"	1.30"
		10	0.39	1/8"		A1-10-A							
		12	0.47			A1-12-A							
2	2	12.7	0.50		1/2"	A2-12.7-A							
		13.5	0.53	1/4"		A2-13.5-A							
		14	0.55			A2-14-A							
		15	0.59			A2-15-A	30mm	40mm	26mm	33mm	48mm	3mm	39mm
		16	0.63		5/8"	A2-16-A	1.18"	1.57"	1.02"	1.30"	1.89"	.12"	1.54"
		17.2	0.67	3/8"		A2-17.2-A							
		18	0.71			A2-18-A							
		19	0.75			A2-19-A							
3	3	19	0.75		3/4"	A3-19-A							
		20	0.79			A3-20-A							
		21.3	0.84	1/2"		A3-21.3-A	30mm	45mm	33mm	35mm	55mm	3mm	41mm
		22	0.87		7/8"	A3-22-A	1.18"	1.69"	1.30"	1.38"	2.17"	.12"	1.61"
		25	0.98			A3-25-A							
		25.4	1.00		1"	A3-25.4-A							
4	4	26.9	1.06	3/4"		A4-26.9-A							
		28	1.10			A4-28-A	30mm	57mm	40mm	42mm	62mm	3mm	48mm
		30	1.18			A4-30-A	1.18"	2.24"	1.57"	1.65"	2.44"	.12"	1.89"
		32	1.25		1 1/4"	A4-32-A							
5	5	32	1.25		1 1/4"	A5-32-A							
		33.7	1.33	1"		A5-33.7-A							
		35	1.38			A5-35-A							
		38	1.50		1 1/2"	A5-38-A	30mm	68mm	52mm	58mm	74mm	3mm	64mm
		40	1.57			A5-40-A	1.18"	2.68"	2.05"	2.28"	2.91"	.12"	2.52"
		42	1.65			A5-42-A							
		42.4	1.67	1 1/4"		A5-42.4-A							
45	1.77			A5-45-A									
6	6	44.5	1.75		1 3/4"	A6-44.5-A	30mm	86mm	66mm	66mm	88mm	3mm	77mm
		48.3	1.90	1 1/2"		A6-48.3-A	1.18"	3.39"	2.60"	2.60"	3.46"	.12"	2.83"
		50.8	2.00		2"	A6-50.8-A							

ADD "S" PREFIX FOR STAINLESS STEEL HARDWARE WHEN ORDERING A COMPLETE CLAMP ASSEMBLY.

STANDARD SERIES – COMPONENTS

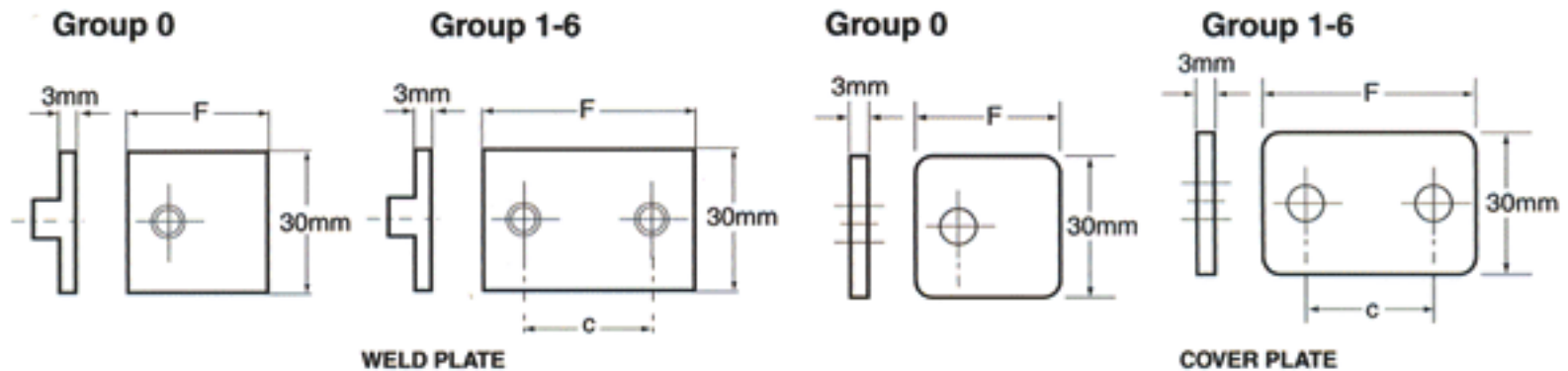

WELD PLATE				COVER PLATE		
GROUP	PART NUMBER	DIMENSIONS		PART NUMBER	DIMENSIONS	
		F	C		F	C
0	WP0	32mm 1.28"	— 0.00"	CP0	28mm 1.10"	— 0.00"
1	WP1	42mm 1.65"	20mm 0.79"	CP1	37mm 1.46"	20mm 0.79"
2	WP2	48mm 1.89"	26mm 1.02"	CP2	43mm 1.69"	26mm 1.02"
3	WP3	55mm 2.17"	33mm 1.30"	CP3	50mm 1.97"	33mm 1.30"
4	WP4	62mm 2.44"	40mm 1.57"	CP4	57mm 2.24"	40mm 1.57"
5	WP5	74mm 2.91"	52mm 2.05"	CP5	69mm 2.72"	52mm 2.05"
6	WP6	88mm 3.46"	66mm 2.60"	CP6	83mm 3.27"	66mm 2.60"

ADD "S" PREFIX FOR STAINLESS STEEL HARDWARE.

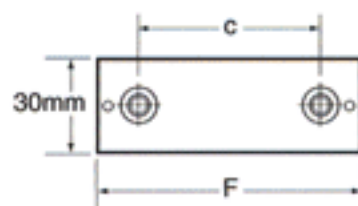

ELONGATED WELD PLATE

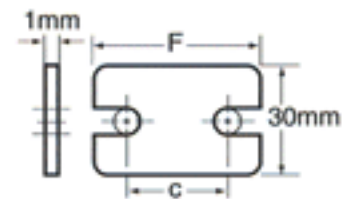

SAFETY PLATE

ELONGATED WELD PLATE					SAFETY PLATE		
GROUP	PART NUMBER	DIMENSIONS			PART NUMBER	DIMENSIONS	
		F	c	d		F	c
0	EWP0	46mm 1.81"	— 0.00"	— 0.00"	SP0	28mm 1.10"	— 0.00"
1	EWP1	64mm 2.52"	20mm 0.79"	50mm 2.01"	SP1	34mm 1.34"	20mm 0.79"
2	EWP2	70mm 2.76"	26mm 1.02"	56mm 2.20"	SP2	41mm 1.61"	26mm 1.02"
3	EWP3	78mm 3.07"	33mm 1.30"	64mm 2.52"	SP3	47mm 1.85"	33mm 1.30"
4	EWP4	86mm 3.39"	40mm 1.57"	71mm 2.80"	SP4	57mm 2.24"	40mm 1.57"
5	EWP5	97mm 3.82"	52mm 2.05"	83mm 3.27"	SP5	67mm 2.64"	52mm 2.05"
6	EWP6	112mm 4.41"	66mm 2.60"	100mm 3.94"	SP6	82mm 3.23"	66mm 2.60"

ADD "S" PREFIX FOR STAINLESS STEEL HARDWARE.

STANDARD SERIES – COMPONENTS

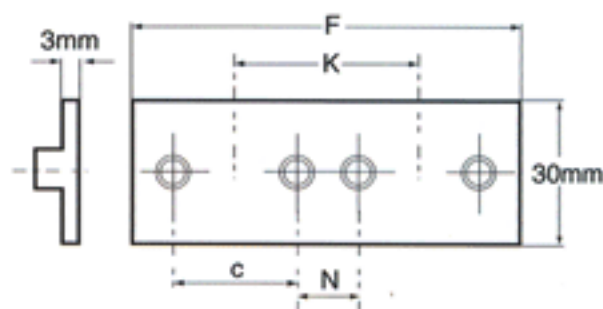

DOUBLE WELD PLATE

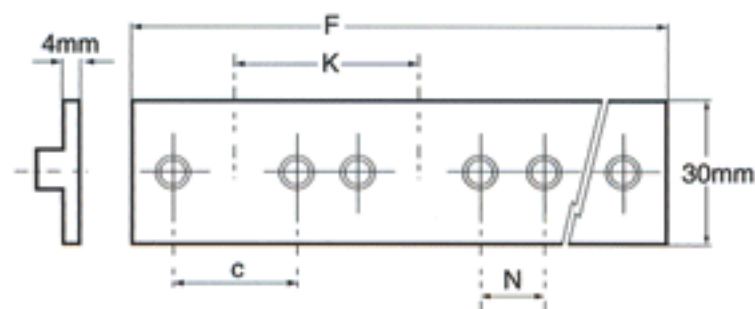

MULTIPLE WELD PLATE

GROUP	PART NUMBER	DIMENSIONS				PART NUMBER	DIMENSIONS				NUMBER OF CLAMPS PER PLATE
		F	C	N	K		F	C	N	K	
0	DWP0	61mm 2.40°	—	—	30mm 1.18°	MWP0	306mm 12.05°	—	—	30mm 1.18°	10
1	DWP1	81mm 3.19°	20mm 0.79°	20mm 0.79°	40mm 1.57°	MWP1	404mm 15.91°	20mm 0.79°	20mm 0.79°	40mm 1.57°	10
2	DWP2	91mm 3.58°	26mm 1.02°	18mm 0.71°	44mm 1.73°	MWP2	447mm 17.60°	26mm 1.02°	18mm 0.71°	44mm 1.73°	10
3	DWP3	106mm 4.17°	33mm 1.30°	19mm 0.75°	52mm 2.05°	MWP3	525mm 20.67°	33mm 1.30°	19mm 0.75°	52mm 2.05°	10
4	DWP4	121mm 4.76°	40mm 1.57°	20mm 0.79°	60mm 2.36°	MWP4	303mm 11.93°	40mm 1.57°	20mm 0.79°	60mm 2.36°	5
5	DWP5	148mm 5.83°	52mm 2.05°	23mm 0.91°	75mm 2.95°	MWP5	375mm 14.76°	52mm 2.05°	23mm 0.91°	75mm 2.95°	5
6	DWP6	177mm 6.97°	66mm 2.60°	24mm 0.94°	90mm 3.54°	MWP6	447mm 17.60°	66mm 2.60°	24mm 0.94°	90mm 3.54°	5

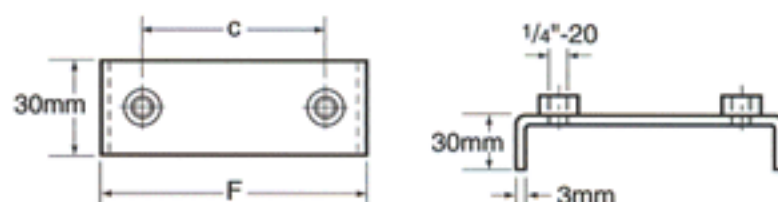
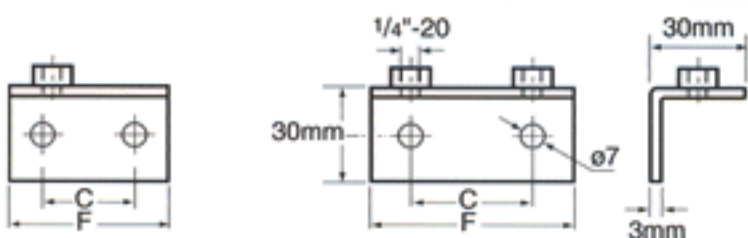

ANGLED WELD PLATE

BRIDGE WELD PLATE

GROUP	PART NUMBER	DIMENSIONS		PART NUMBER	DIMENSIONS	
		F	C		F	C
0	AWP0	32mm 1.26°	14mm 0.55°	—	—	—
1	AWP1	42mm 1.65°	20mm 0.79°	BWP1	48mm 1.89°	20mm 0.79°
2	AWP2	48mm 1.89°	26mm 1.02°	BWP2	54mm 2.13°	26mm 1.02°
3	AWP3	55mm 2.17°	33mm 1.30°	BWP3	62mm 2.44°	33mm 1.30°
4	AWP4	62mm 2.44°	40mm 1.57°	BWP4	71mm 2.80°	40mm 1.57°
5	AWP5	74mm 2.91°	52mm 2.05°	BWP5	85mm 3.35°	52mm 2.05°
6	AWP6	88mm 3.46°	66mm 2.60°	BWP6	98mm 3.86°	66mm 2.60°

STANDARD SERIES – COMPONENTS

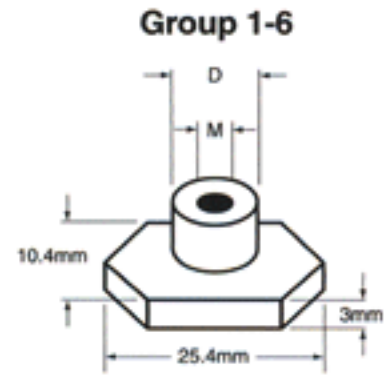
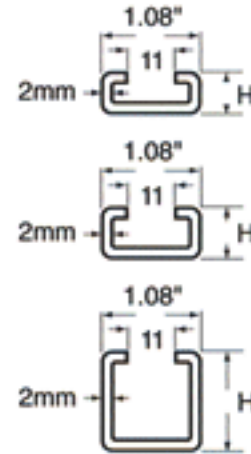

GROUP	HEX HEAD BOLT	SOCKET HEAD CAP SCREW	STACKING BOLT	MOUNTING RAIL		RAIL NUT	
	PART NUMBER SIZE	PART NUMBER SIZE	PART NUMBER SIZE	PART NUMBER HEIGHT H	PART NUMBER LENGTH L	PART NUMBER M	PART NUMBER D
0	HB0/1 1/4"-20 x 1 1/4"	SC0/1 1/4"-20 x 3/4"	SB0/1 1/4"-20 x 3/4"	MR-11-1 11 0.43	1M 3.28	RNS/T1 1/4"-20	12mm 0.47"
1	HB0/1 1/4"-20 x 1 1/4"	SC0/1 1/4"-20 x 3/4"	SB0/1 1/4"-20 x 3/4"	MR-11-2 11 0.43	2M 6.56		
2	HB2 1/4"-20 x 1 3/8"	SC2 1/4"-20 x 1"	SB2 1/4"-20 x 1"	MR-14-1 14 0.55	1M 3.28		
3	HB3 1/4"-20 x 1 1/2"	SC3 1/4"-20 x 1 1/4"	SB3 1/4"-20 x 1 1/4"	MR-14-2 14 0.55	1M 6.56		
4	HB4 1/4"-20 x 1 3/4"	SC4 1/4"-20 x 1 3/8"	SB4 1/4"-20 x 1 3/8"	MR-30-1 30 1.18	1M 3.28		
5	HB5 1/4"-20 x 2 1/2"	SC5 1/4"-20 x 2"	SB5 1/4"-20 x 2"	MR-30-2 30 1.18	2M 6.56		
6	HB6 1/4"-20 x 2 3/4"	SC6 1/4"-20 x 2 3/8"	SB6 1/4"-20 x 2 3/8"				

ADD "S" PREFIX FOR STAINLESS STEEL BOLTS.

TWIN SERIES CLAMPS – ORDERING EXAMPLE

****AT4 – 26.9 – A**

CLAMP SET MATERIAL

Polypropylene (Green) AT
 Polyamide* MT
 Rubber* RT

* SPECIAL ORDER

DESCRIPTION

A Clamp with Weld Plate & Cover Plate
SK Clamp with Stacking Kit
R Clamp with Rail Nuts & Cover Plate
 Clamp Set Only

GROUP SIZE

Refer to Chart on Page 92

CLAMP SET BORE

Pipe and tube clamp sizes have a profiled bore. For hose and special applications add "H" to the part number for a smooth bore.

CLAMP SET ID

Refer to Chart on Page 92

**"S" PREFIX = STAINLESS STEEL HARDWARE AVAILABLE BY SPECIAL ORDER ONLY.

A

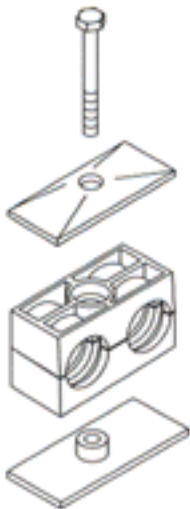

SK

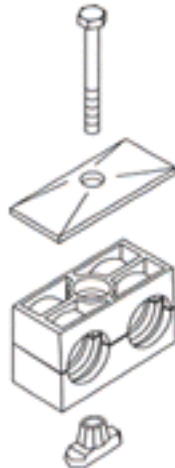

R

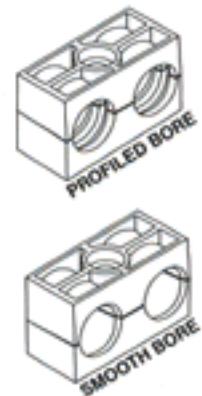

ⓘ

ⓘ NOT AVAILABLE IN ALL SIZES. CONTACT PCI FOR AVAILABILITY.

TWIN SERIES – SIZES AND DIMENSIONS

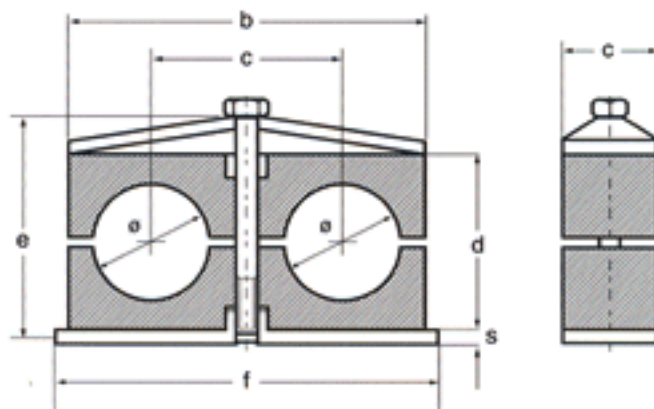

PCI		DIN		DIAMETER			DIMENSIONS						
GROUP	GROUP	Ø mm	Ø Inch	PIPE NOMINAL BORE	TUBE O.D.	PART #	A	B	C	D	F	S	H
1	1	6	0.24			AT1-06-A							
		6.4	0.25		1/4"	AT1-6.4-A							
		8	0.31		5/16"	AT1-08-A	30mm	37mm	20mm	25mm	37mm	3mm	35mm
		9.5	0.37		3/8"	AT1-9.5-A	1.18"	1.46"	.79"	.98"	1.46"	.12"	1.36"
		10	0.39	1/8"		AT1-10-A							
		12	0.47			AT1-12-A							
2	2	12.7	0.50		1/2"	AT2-12.7-A							
		13.5	0.53	1/4"		AT2-13.5-A							
		14	0.55			AT2-14-A							
		15	0.59			AT2-15-A							
		16	0.63		5/8"	AT2-16-A	30mm	53mm	29mm	26mm	55mm	5mm	36mm
		17.2	0.67	3/8"		AT2-17.2-A	1.18"	2.09"	1.14"	1.02"	2.17"	.20"	1.42"
3	3	19	0.75		3/4"	AT3-19-A							
		20	0.79			AT3-20-A							
		21.3	0.84	1/2"		AT3-21.3-A	30mm	67mm	36mm	37mm	70mm	5mm	47mm
		22	0.87		7/8"	AT3-22-A	1.18"	2.64"	1.42"	1.46"	2.76"	.20"	1.85"
		25	0.98			AT3-25-A							
		25.4	1.00		1"	AT3-25.4-A							
4	4	26.9	1.06	3/4"		AT4-26.9-A							
		28	1.10			AT4-28-A	30mm	82mm	45mm	42mm	85mm	5mm	52mm
		30	1.18			AT4-30-A	1.18"	3.23"	1.77"	1.65"	3.35"	.20"	2.05"
5	5	32	1.25		1 1/4"	AT5-32-A							
		33.7	1.33	1"		AT5-33.7-A							
		35	1.38			AT5-35-A							
		38	1.50		1 1/2"	AT5-38-A	30mm	106mm	56mm	54mm	110mm	5mm	64mm
		40	1.57			AT5-40-A	1.18"	4.17"	2.20"	2.13"	4.33"	.20"	2.52"
		42	1.65			AT5-42-A							
42.4	1.67	1 1/4"		AT5-42.4-A									

ADD "S" PREFIX FOR STAINLESS STEEL HARDWARE. SPECIAL ORDER ONLY.

TWIN SERIES – COMPONENTS

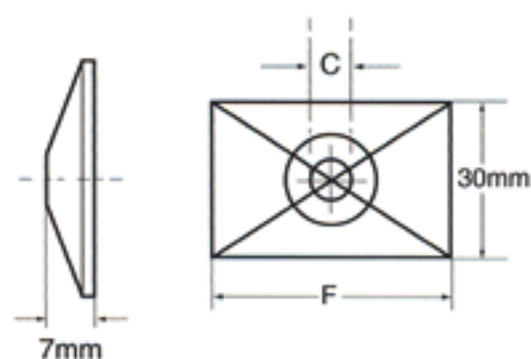
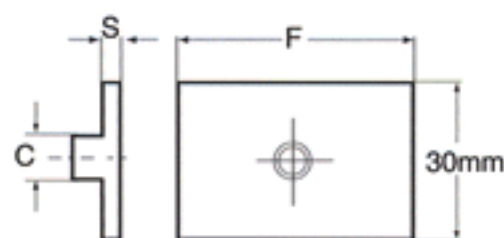

WELD PLATE

COVER PLATE

GROUP	PART NUMBER	DIMENSIONS			PART NUMBER	DIMENSIONS	
		F	C	S		F	C
1	WPT1	37mm 1.46"	12mm 0.79"	3mm 0.12"	CPT1	35mm 1.38"	7mm 0.28"
2	WPT2	55mm 2.17"	14mm 0.55"	5mm 0.20"	CPT2	52mm 2.05"	9mm 0.35"
3	WPT3	70mm 2.76"	14mm 0.55"	5mm 0.20"	CPT3	66mm 2.60"	9mm 0.35"
4	WPT4	85mm 3.35"	14mm 0.55"	5mm 0.20"	CPT4	81mm 3.19"	9mm 0.35"
5	WPT5	110mm 4.33"	14mm 0.55"	5mm 0.20"	CPT5	105mm 4.13"	9mm 0.35"

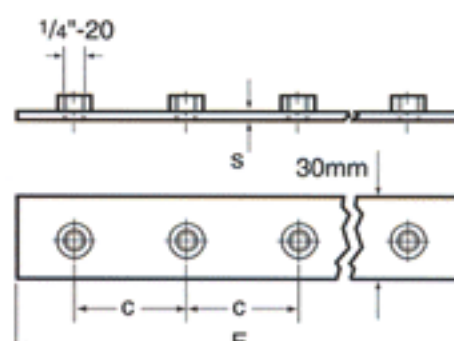
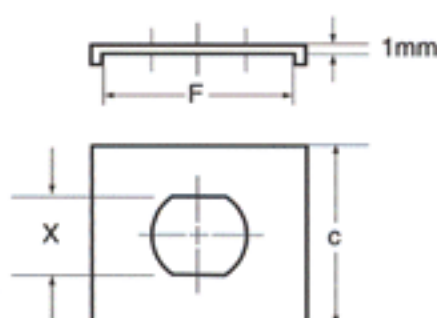

SECURITY PLATE

MULTIPLE WELD PLATE

GROUP	PART NUMBER	DIMENSIONS			PART NUMBER	DIMENSIONS			NUMBER OF CLAMPS PER PLATE
		F	C	X		F	C	S	
1	SPT1	30mm 1.18"	30mm 1.18"	11mm 0.43"	MWPT1	200mm 7.87"	40mm 1.57"	3mm 0.12"	5
2	SPT2	30mm 1.18"	30mm 1.18"	13mm 0.51"	MWPT2	290mm 11.42"	58mm 2.28"	5mm 0.20"	5
3	SPT3	30mm 1.18"	30mm 1.18"	13mm 0.51"	MWPT3	360mm 14.17"	72mm 2.83"	5mm 0.20"	5
4	SPT4	30mm 1.18"	30mm 1.18"	13mm 0.51"	MWPT4	450mm 17.72"	90mm 3.54"	5mm 0.20"	5
5	SPT5	30mm 1.18"	30mm 1.18"	13mm 0.51"	MWPT5	560mm 22.05"	112mm 4.41"	5mm 0.20"	5

TWIN SERIES – COMPONENTS

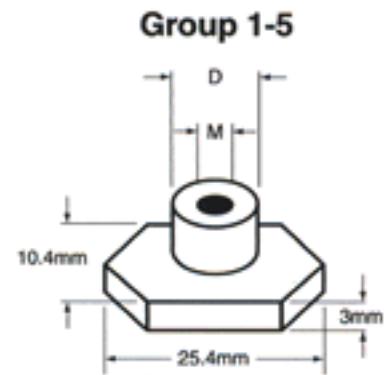
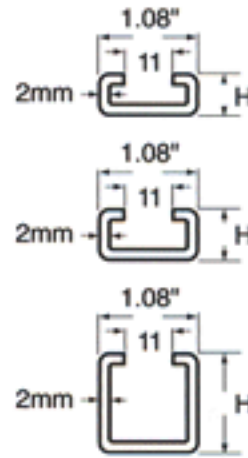

GROUP	HEX HEAD BOLT	STACKING BOLT	MOUNTING RAIL		RAIL NUT	
	PART NUMBER SIZE	PART NUMBER SIZE	PART NUMBER HEIGHT H	PART NUMBER LENGTH L	PART NUMBER M	PART NUMBER D
1	HB2/T1 1/4"-20 x 13/8"	SBT/1 1/4"-20 x .79"	MR-11-2 11 0.43	2M 6.56	RNS/T1 1/4"-20	12mm 0.47"
2	HBT/2 5/16"-18 x 13/8"	SBT/2 5/16"-18 x .79"	MR-14-1 14 0.55	1M 3.28	RNT2/5 5/16"-18	14mm 0.55"
3	HBT/3 5/16"-18 x 13/4"	SBT/3 5/16"-18 x 1.14"	MR-14-2 14 0.55	1M 6.56		
4	HBT/4 5/16"-18 x 2"	SBT/4 5/16"-18 x 1.34"	MR-30-1 30 1.18	1M 3.28		
5	HBT/5 5/16"-18 x 2 1/2"	SBT/5 5/16"-18 x 1.85"	MR-30-2 30 1.18	2M 6.56		

HEAVY DUTY SERIES CLAMPS – ORDERING EXAMPLE

****AH3 – 33.7 – A**

CLAMP SET MATERIAL	
Polypropylene	A
Aluminum	LA
Polyamide*	MA
Rubber*	RA

* SPECIAL ORDER

DESCRIPTION	
A	Clamp with Weld Plate & Cover Plate
SK	Clamp with Stacking Kit
R	Clamp with Rail Nuts & Cover Plate
D	Double Clamp with Weld Plate & Cover Plate
	Clamp Set Only

GROUP SIZE
Refer to Chart on Page 96-97

CLAMP SET BORE
Pipe and tube clamp sizes have a profiled bore. For hose and special applications add "H" to the part number for a smooth bore.

CLAMP SET ID
Refer to Chart on Page 96-97

**"S" PREFIX = STAINLESS STEEL HARDWARE. AVAILABLE BY SPECIAL ORDER ONLY.

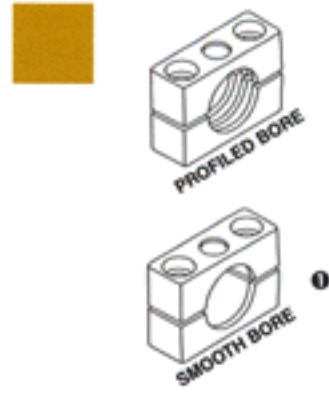
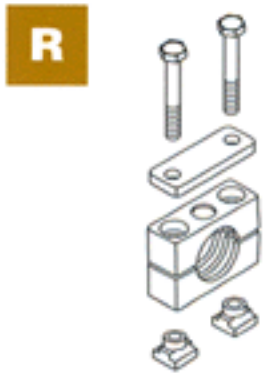
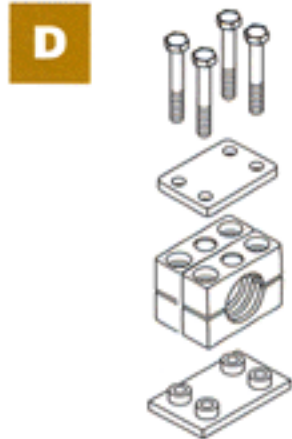
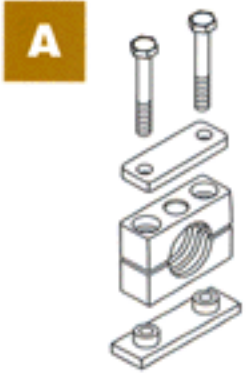

Ⓢ NOT AVAILABLE IN ALL SIZES. CONTACT PCI FOR AVAILABILITY.

HEAVY DUTY SERIES – SIZES AND DIMENSIONS

GROUP 1-4

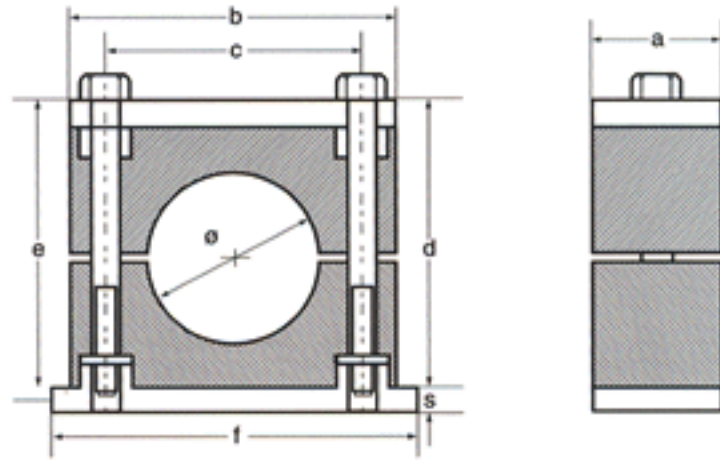

PCI		DIN		DIAMETER			DIMENSIONS						
GROUP	GROUP	Ø mm	Ø Inch	PIPE NOMINAL BORE	TUBE O.D.	PART #	A	B	C	D	F	S	E
1	1	6	0.24			AH1-06-A							
		6.4	0.25		1/4"	AH1-6.4-A							
		8	0.31		5/16"	AH1-08-A							
		9.5	0.37		3/8"	AH1-9.5-A							
		10	0.39	1/8"		AH1-10-A							
		12	0.47			AH1-12-A	30mm	55mm	33mm	32mm	73mm	8mm	48mm
		12.7	0.50		1/2"	AH1-12.7-A	1.18"	2.17"	1.30"	1.26"	2.87"	0.31"	1.89"
		13.5	0.53	1/4"		AH1-13.5-A							
		14	0.55			AH1-14-A							
		15	0.59			AH1-15-A							
16	0.63		5/8"	AH1-16-A									
17.2	0.68	3/8"		AH1-17.2-A									
18	0.71			AH1-18-A									
2	2	19	0.75		3/4"	AH2-19-A							
		20	0.79			AH2-20-A							
		21.3	0.84	1/2"		AH2-21.3-A							
		22	0.87		7/8"	AH2-22-A							
		25	0.98			AH2-25-A	30mm	70mm	45mm	48mm	85mm	8mm	76mm
		25.4	1.00		1"	AH2-25.4-A	1.18"	2.76"	1.77"	1.89"	3.35"	0.31"	2.52"
		26.9	1.06	3/4"		AH2-26.9-A							
28	1.10			AH2-28-A									
30	1.18			AH2-30-A									
3	3	30	1.18			AH3-30-A							
		32	1.25		1 1/4"	AH3-32-A							
		33.7	1.33	1"		AH3-33.7-A							
		35	1.38			AH3-35-A	30mm	85mm	60mm	60mm	100mm	8mm	76mm
		38	1.50		1 1/2"	AH3-38-A	1.18"	3.35"	2.36"	2.36"	3.94"	0.31"	2.99"
		40	1.57			AH3-40-A							
		42	1.65			AH3-42-A							
42.4	1.67	1 1/4"		AH3-42.4-A									
4	4	38	1.50		1 1/2"	AH4-38-A							
		42	1.65			AH4-42-A							
		42.4	1.67	1 1/4"		AH4-42.4-A							
		44.5	1.75		1 3/4"	AH4-44.5-A							
		48.3	1.90	1 1/2"		AH4-48.3-A							
		50	1.97			AH4-50-A	45mm	120mm	90mm	90mm	140mm	10mm	110mm
		50.8	2.00		2"	AH4-50.8-A	1.77"	4.72"	3.54"	3.54"	5.51"	0.39"	4.33"
		55	2.17			AH4-55-A							
		57	2.24		2 1/4"	AH4-57-A							
		60.3	2.37	2"		AH4-60.3-A							
63.5	2.50		2 1/2"	AH4-63.5-A									
65	2.56			AH4-65-A									
70	2.76		2 3/4"	AH4-70-A									

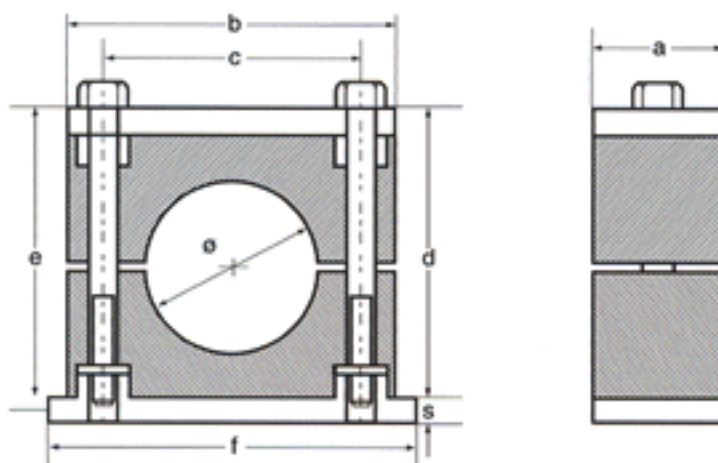

PCI	DIN	DIAMETER					DIMENSIONS						
GROUP	GROUP	Ø mm	Ø Inch	PIPE NOMINAL BORE	TUBE O.D.	PART #	A	B	C	D	F	S	E
5	5	65	2.56			AH5-65-A	60mm 2.38"	152mm 5.98"	122mm 4.80"	120mm 4.72"	180mm 7.09"	10mm 0.39"	140mm 5.51"
		70	2.76		2 ³ / ₄ "	AH5-70-A							
		73	2.87	2 ¹ / ₂ "		AH5-73-A							
		75	2.95			AH5-75-A							
		76.1	3.00	2 ¹ / ₂ "	3"	AH5-76.1-A							
		80	3.15			AH5-80-A							
		82.5	3.25		3 ¹ / ₄ "	AH5-82.5-A							
		88.9	3.50	3"	3 ¹ / ₂ "	AH5-88.9-A							
6	6	88.9	3.50	3"	3 ¹ / ₂ "	AH6-88.9-A	80mm 3.15"	205mm 8.07"	168mm 6.61"	170mm 6.69"	225mm 8.86"	15mm 0.59"	200mm 7.87"
		100	3.94			AH6-100-A							
		101.6	4.00	3 ¹ / ₂ "	4"	AH6-101.6-A							
		108	4.25		4 ¹ / ₄ "	AH6-108-A							
		114.3	4.50	4"	4 ¹ / ₂ "	AH6-114.3-A							
		127	5.00	4 ¹ / ₂ "	5"	AH6-127-A							
133	5.25		5 ¹ / ₄ "	AH6-133-A									
7	7	133	5.25		5 ¹ / ₄ "	AH7-133-A	90mm 3.54"	250mm 9.84"	205mm 8.07"	200mm 7.87"	270mm 10.63"	15mm 0.59"	230mm 9.06"
		139.7	5.50	5"	5 ¹ / ₂ "	AH7-139.7-A							
		152.4	6.00	5 ¹ / ₂ "	6"	AH7-152.4-A							
		165	6.50			AH7-165-A							
168.3	6.63	6"		AH7-168.3-A									
8	8	168.3	6.63	6"		AH8-168.3-A	120mm 4.72"	320mm 12.60"	265mm 10.43"	270mm 10.63"	340mm 13.39"	25mm 0.98"	320mm 12.60"
		177.8	7.00			AH8-177.8-A							
		193.7	7.63		7 ⁵ / ₈ "	AH8-193.7-A							
		203	8.00		8"	AH8-203-A							
		216	8.50			AH8-216-A							
219.1	8.63	8"		AH8-219.1-A									
9*	9*	219.1	8.63	8"		AH9-219.1-A	160mm 6.30"	470mm 18.50"	395mm 15.55"	410mm 16.14"	520mm 20.47"	30mm 1.18"	470mm 18.50"
		244.5	9.63			AH9-244.5-A							
		273	10.75	10"		AH9-273-A							
		323.9	12.75	12"		AH9-323.9-A							

* SPECIAL ORDER

HEAVY DUTY SERIES – COMPONENTS

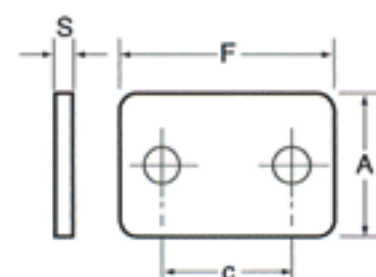
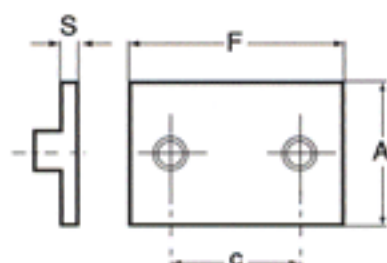

WELD PLATE

COVER PLATE

GROUP	PART NUMBER	DIMENSIONS				PART NUMBER	DIMENSIONS			
		A	F	C	S		A	F	C	S
1	WPH1	30mm 1.18"	75mm 2.95"	3mm 1.30"	8mm 0.31"	CPH1	30mm 1.18"	55mm 2.17"	33mm 1.30"	8mm 0.31"
2	WPH2	30mm 1.18"	87mm 3.43"	45mm 1.77"	8mm 0.31"	CPH2	30mm 1.18"	70mm 2.76"	45mm 1.77"	8mm 0.31"
3	WPH3	30mm 1.18"	102mm 4.02"	60mm 2.36"	8mm 0.31"	CPH3	30mm 1.18"	85mm 3.35"	60mm 2.36"	8mm 0.31"
4	WPH4	45mm 1.77"	140mm 5.51"	90mm 3.54"	10mm 0.39"	CPH4	45mm 1.77"	120mm 4.72"	90mm 3.54"	10mm 0.39"
5	WPH5	60mm 2.36"	180mm 7.09"	122mm 4.80"	10mm 0.39"	CPH5	60mm 2.36"	152mm 5.98"	122mm 4.80"	10mm 0.39"
6	WPH6	80mm 3.15"	225mm 8.86"	168mm 6.61"	15mm 0.59"	CPH6	80mm 3.15"	205mm 8.07"	168mm 6.61"	15mm 0.59"
7	WPH7	90mm 3.54"	270mm 10.63"	205mm 8.07"	15mm 0.59"	CPH7	90mm 3.54"	250mm 9.84"	205mm 8.07"	15mm 0.59"
8	WPH8	120mm 4.72"	340mm 13.39"	265mm 10.43"	25mm 0.98"	CPH8	120mm 4.72"	320mm 12.60"	265mm 10.43"	25mm 0.98"
9	WPH9	160mm 6.30"	520mm 20.47"	395mm 15.55"	30mm 1.18"	CPH9	160mm 6.30"	470mm 18.50"	395mm 15.55"	30mm 1.18"

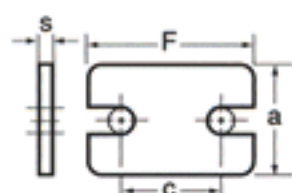

SAFETY PLATE

GROUP	PART NUMBER	DIMENSIONS			
		A	F	C	S
1	SPH1	30mm 1.18"	55mm 2.17"	33mm 1.30"	8mm 0.31"
2	SPH2	30mm 1.18"	70mm 2.76"	45mm 1.77"	8mm 0.31"
3	SPH3	30mm 1.18"	85mm 3.35"	60mm 2.36"	8mm 0.31"
4	SPH4	45mm 1.77"	120mm 4.72"	90mm 3.54"	10mm 0.39"
5	SPH5	60mm 2.36"	152mm 5.98"	122mm 4.80"	10mm 0.39"

HEAVY DUTY SERIES – COMPONENTS

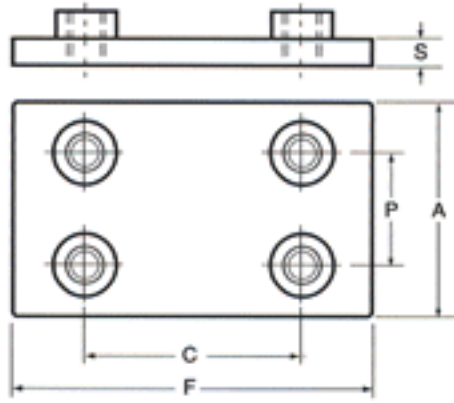

DOUBLE WELD PLATE

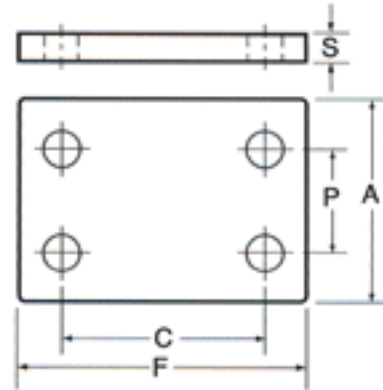

DOUBLE COVER PLATE

GROUP	PART NUMBER	DIMENSIONS					PART NUMBER	DIMENSIONS				
		A	F	S	C	P		A	F	C	S	P
1	WPHD1	60mm 2.36"	74mm 2.91"	8mm 0.31"	33mm 1.30"	31mm 1.22"	CPHD1	60mm 2.36"	56mm 2.20"	8mm 0.31"	33mm 1.30"	31mm 1.22"
2	WPHD2	60mm 2.36"	85mm 3.39"	8mm 0.31"	45mm 1.77"	31mm 1.22"	CPHD2	60mm 2.36"	70mm 2.76"	8mm 0.31"	45mm 1.77"	31mm 1.22"
3	WPHD3	60mm 2.36"	100mm 3.94"	8mm 0.31"	60mm 2.36"	31mm 1.22"	CPHD3	60mm 2.36"	85mm 3.35"	8mm 0.31"	60mm 2.36"	31mm 1.22"
4	WPHD4	90mm 3.54"	140mm 5.51"	10mm 0.39"	90mm 3.54"	46mm 1.81"	CPHD4	90mm 3.54"	116mm 4.57"	10mm 0.39"	90mm 3.54"	46mm 1.81"
5	WPHD5	120mm 4.72"	160mm 7.09"	10mm 0.39"	122mm 4.80"	61mm 2.40"	CPHD5	120mm 4.72"	153mm 6.02"	10mm 0.39"	122mm 4.80"	61mm 2.40"

HEAVY DUTY SERIES – COMPONENTS

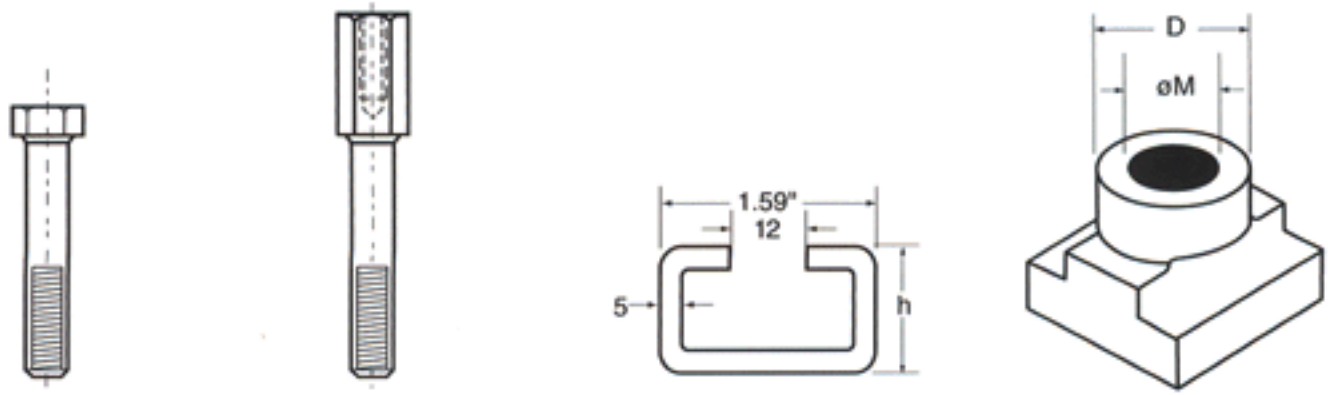

GROUP	HEX HEAD BOLT	STACKING BOLT	MOUNTING RAIL		RAIL NUT	
	PART NUMBER SIZE	PART NUMBER SIZE	HEIGHT H	PART NUMBER LENGTH L	PART NUMBER M	PART NUMBER D
1	HBH1 3/8"-16 x 13/4"	SBH1 3/8"-16 x 1.02"	22 0.87	MRH-1 1M 3.28'	RNH1/3 3/8"-16	18 0.71
2	HBH2 3/8"-16 x 2 1/4"	SBH2 3/8"-16 x 1.61"	22 0.87	MRH-2 2M 6.56'	RNH1/3 3/8"-16	18 0.71
3	HBH3 3/8"-16 x 2 3/4"	SBH3 3/8"-16 x 2.05"			RNH1/3 3/8"-16	18 0.71
4	HBH4 7/16"-14 x 4"	SBH4 7/16"-14 x 3.27"			RNH4 7/16"-14	20 0.79
5	HBH5 5/8"-11 x 5 1/4"	SBH5 5/8"-11 x 4.33"				
6	HBH6 3/4"-10 x 7 1/2"					
7	HBH7 7/8"-9 x 8 1/2"					
8	HBH8 1 1/8"-7 x 12"					
9	HBH9 1 1/8"-7 x 17 1/2"					